

AA Breakdown Repair Cover

(also known as Parts and Garage Cover)

**Terms & Conditions Booklet
and Arrangement & Administration Contract**

September 2018

Important information: Please read and retain

AA

Welcome to AA Breakdown Repair Cover

Welcome to AA Breakdown Repair Cover

We know that repairs can be an unexpected cost. That's why we created Breakdown Repair Cover to help with these. It pays for many of the spare parts we use to fix your vehicle at the roadside that we'd normally charge you for, or it can help cover the costs for work that's done in a garage after a breakdown. All you need to do is call the AA out to attend the breakdown (or have your Car Genie device notify you) under the terms of your AA membership.

If you have any questions give us a call on 0344 579 0042.

Please note that for reasons of quality assurance and compliance, calls may be recorded and monitored.

A little bit about your Breakdown Repair Cover policy provider

So who exactly is providing your AA Breakdown Repair Cover? Well, your cover has been arranged by Automobile Association Insurance Services Limited (AAIS). This operates as an insurance intermediary, authorised and regulated by the Financial Conduct Authority. Its registered office is at Fanum House, Basing View, Basingstoke, Hampshire RG21 4EA. Registered in England number 2414212.

Any claims you make under your AA Breakdown Repair Cover will be managed by Automobile Association Insurance Services Limited.

The insurer of Your AA Breakdown Repair Cover is Acromas Insurance Company Limited, 57-63 Line Wall Road, Gibraltar. Registered number 88716 (Gibraltar). UK branch address: Enbrook Park, Sandgate, Folkstone CT20 3SE. Acromas Insurance Company Limited is authorised by the Financial Services Commission, Gibraltar and is a member of the Association of British Insurers.

Demands and Needs

Our Breakdown Repair Cover (Parts and Garage Cover) is designed to meet the needs of a customer who requires a contribution towards repair costs following a breakdown.

For claims please call 0344 579 0042

Information is available in large print, audio and braille on request. Please call 0800 262 050 for details. Deaf, hard of hearing or speech-impaired Members may contact us using Text Relay.

Contents

| | |
|---|---------|
| How to make a claim | page 4 |
| PART 1: AA BREAKDOWN REPAIR COVER POLICY – YOUR CONTRACT WITH THE INSURER | |
| ▶ Your policy in detail | page 7 |
| • Definitions..... | page 8 |
| • Your limits and cover..... | page 9 |
| • General exclusions (this policy will not cover)..... | page 12 |
| • General conditions applicable to this policy | page 13 |
| Period of cover..... | page 13 |
| Limitations to cover | page 13 |
| Claims or repair authorisation..... | page 13 |
| Fraudulent claims..... | page 14 |
| Cancellation rights and procedures..... | page 14 |
| Law and language | page 15 |
| ▶ Frequently asked questions | page 16 |
| ▶ If you need to complain..... | page 17 |
| PART 2: AA BREAKDOWN REPAIR COVER ARRANGEMENT & ADMINISTRATION CONTRACT – YOUR CONTRACT WITH AUTOMOBILE ASSOCIATION INSURANCE SERVICES LIMITED (AAIS): | |
| ▶ Who regulates AAIS?..... | page 19 |
| ▶ Which companies does AAIS deal with? | page 19 |
| ▶ What services does AAIS provide? | page 19 |
| ▶ What will you have to pay for services provided by AAIS? | page 20 |
| ▶ Changes to Terms & Conditions | page 20 |
| ▶ Matters outside AAIS’s reasonable control | page 20 |
| ▶ Exclusion of liability for loss of profit etc. | page 20 |
| ▶ Third parties..... | page 21 |
| ▶ Interpretation: use of English law & language..... | page 21 |
| ▶ What to do if you have a complaint? | page 21 |
| ▶ Is AAIS covered by the Financial Services Compensation Scheme (FSCS)?..... | page 21 |
| ▶ Use of headings..... | page 21 |
| Use of your personal information | page 22 |
| Company details | page 23 |

How to make a claim

If you breakdown and we can't fix your vehicle at the roadside – here's where your AA Breakdown Repair Cover comes in. Making a claim is easy – just follow the steps shown here.

Step 1. Breakdown

If your vehicle breaks down, use your AA membership and call for AA Assistance on 0800 88 77 66. It's important to do this as under the terms of your AA Breakdown Repair Cover policy you must do so before trying to claim.

Step 2. Vehicle can't be fixed at roadside

Your AA mobile mechanic will arrive as soon as possible and will try to fix your vehicle there and then. If your vehicle can't be fixed at the roadside and needs to be taken to a garage, you'll need to call the AA Breakdown Repair claims helpline on 0344 579 0042.

Step 3. Getting your vehicle to a repairer

Whenever possible we'll get your vehicle taken to one of our network of preferred garages for repair. Alternatively, if you prefer, we can get your vehicle to a professional repairer of your choice.

There are lots of benefits of the Breakdown Repair Cover Garage Network and your claims advisor can tell you about them and which garages are in the scheme.

Step 4. Agreeing on necessary repairs

Before any repairs are started you and the repairer must agree on what needs to be done and these repairs must then be authorised by the Breakdown Repair Cover claim handler. Once everything's agreed and authorised you'll get a claim authorisation number – please keep this number safe as you may need to refer to it. In some circumstances it may be necessary to appoint an independent engineer to inspect the vehicle to assess whether the claim falls within the terms and conditions of your cover.

Claims should be sent to the following address: AA Claims Services, Lambert House, Stockport Road, Cheadle, Cheshire, SK8 2DY.

For claims please call 0344 579 0042

**Part 1: AA Breakdown Repair Cover Policy – Your contract
with the insurer**

1. YOUR POLICY IN DETAIL

Introduction to your AA Breakdown Repair cover

Breakdown Repair Cover is an optional extra available to your AA membership and is insured by Acromas Insurance Company limited.

The cover set out in the policy is designed to run alongside your AA membership, to cover the cost of parts, which require replacing or repairing, following a breakdown attended by the AA.

This cover is not a warranty and is not intended to replace servicing.

It is a requirement that any vehicles covered under this policy are serviced regularly in line with the manufacturer's recommended schedules.

Acromas Insurance Company Limited has agreed to insure you for the cost of claims made under this policy subject to the terms, conditions and exclusions in this AA Breakdown Repair Cover booklet and for which you have paid or agreed to pay the required premium.

Your AA Breakdown Repair Cover welcome letter and this booklet should be read together as one document as it forms your insurance cover. Acromas Insurance Company Limited has relied on the information and statements you provided to Automobile Association Insurance Services Limited when agreeing to provide your cover. Please read your documents carefully to make sure the information is correct and that the cover meets your needs.

For claims please call 0344 579 0042

Definitions

AA: Automobile Association Developments Limited (trading as AA Breakdown Services) or, where appropriate, its agents.

AAIS: Automobile Association Insurance Services Limited.

AA membership: the cover You have arranged for assistance in the event of a breakdown involving the Nominated Vehicle noted on the letter accompanying this policy booklet and Your membership card.

Breakdown: A sudden or unexpected event involving the Nominated Vehicle:

- a) as a result of Mechanical or Electrical Failure; and
- b) which has been attended by the AA under Your AA membership; and
- c) that has prevented the Nominated Vehicle from starting or continuing its journey safely; and
- d) that requires the repair or replacement of insured part(s) to enable the journey to be resumed or, when At Home (Home Start) cover is held under Your AA membership, commenced

Claims Department: The department which will assess, authorise and arrange payment of Your claim.

Insurer: Acromas Insurance Company Limited

Mechanical or Electrical Failure: The sudden and unforeseen breaking or burning out (electrical) of any insured part(s).

Modified Part: Any part fitted by you or with your knowledge that is not to the manufacturer's standard specification.

Multiple Vehicle Cover: Cover for a maximum of four Nominated Vehicles at any one time.

Nominated Vehicle: A car, van, motorhome or motorcycle, whose vehicle registration number is detailed on the letter accompanying Your policy booklet that is also eligible for breakdown assistance under Your AA membership but excluding caravans and other trailers, kit cars and any vehicles used to carry goods for reward including taxis and vehicles used for driving instruction and those used to carry goods for reward including haulage, the provision of courier services, or parcel delivery.

Paid Claim: A claim We have authorised for insured parts which directly caused the Nominated Vehicle to break down and prevented it from being able to resume or commence (when At Home Home Start cover is held under Your AA membership) its journey safely.

Period of Insurance: The period for which the Insurer has agreed to cover You and for which You have paid the required premium.

Policy Excess: The amount You are required to pay towards any claim made under this policy.

Policy Start Date: The date on which the policy was purchased and the required premium was paid.

Service Items: Parts that are specifically designed to wear or are replaced as part of the vehicle's standard maintenance. A list of common 'service items' is contained in this booklet on page 15.

We/Us: The Insurer

You/Your: The person holding the AA membership and Breakdown Repair Cover.

Your Limits and cover

Please note that Mechanical or Electrical Failures must cause a sudden and unexpected Breakdown, this policy will not cover failures that You were previously aware of or have been made aware of or that are not directly related to the cause of the Breakdown.

What is covered?

The insurer will pay up to £535 per Paid Claim towards the costs of repair or replacement to insured parts, labour and VAT following a Breakdown which occurs during the Period of Insurance.

The Breakdown must occur in the United Kingdom (meaning England, Scotland, Wales and Northern Ireland only).

What is not covered?

1. Your £35 Policy Excess.
2. Any claim, which occurs within 14 days of Your Policy Start Date or within 14 days from the date You notify the AA of a change or addition of a Nominated Vehicle.
3. Damage caused to an excluded or Modified Part or any consequential damage caused by an excluded or modified part.
4. a) More than five Paid Claims in each 12 month period of cover when individual AA membership is held; or
b) More than six Paid Claims in each 12 month period of cover if Multiple Vehicle Cover is held with Joint or Family AA membership.
5. Vehicles that are not specified on an individual insurance policy or are used as part of the Motor Trade.

For claims please call 0344 579 0042

Parts insured under AA Breakdown Repair Cover

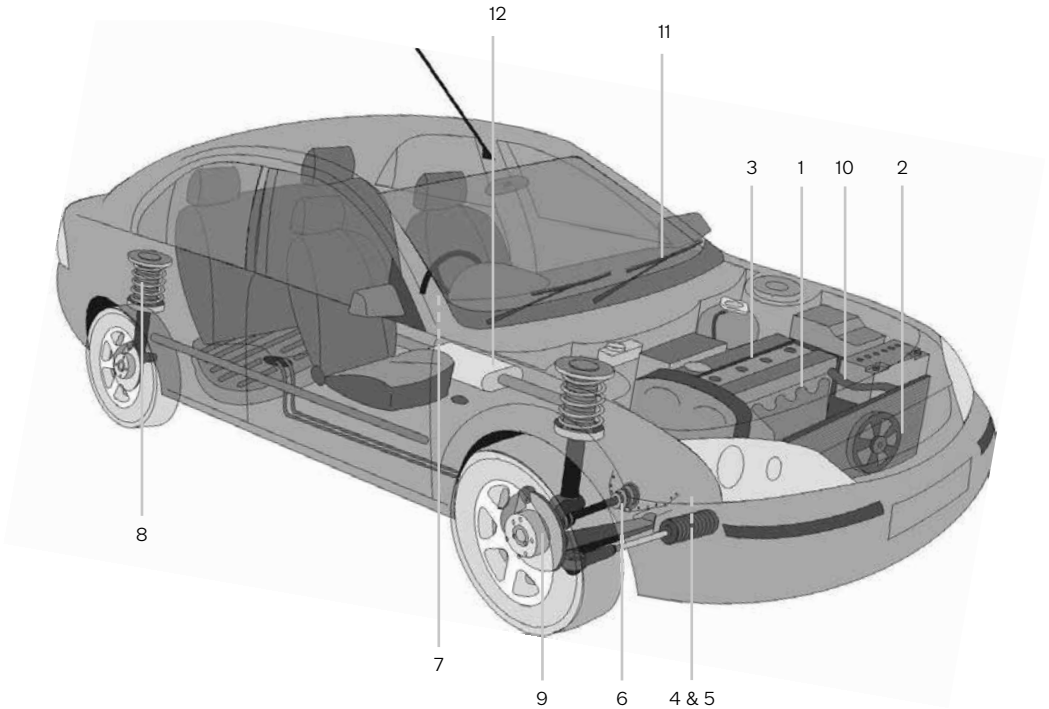

For claims please call 0344 579 0042

| | Parts covered | Parts not covered |
|-----|-----------------------------|---|
| 1. | The Engine | |
| 2. | Engine Cooling System | |
| 3. | Fuel System | Fuel particulate filters Damage or failure due to incorrect or contaminated fuel. |
| 4. | Clutch | Worn out friction surfaces |
| 5. | Gearbox | |
| 6. | Differential and Drive Line | |
| 7. | Steering | |
| 8. | Suspension | |
| 9. | Braking System | Brake pads, discs, drums and shoes. |
| 10. | Electrical System | Sun roof motors and mechanisms, folding roof mechanisms, door and boot locks and lock mechanisms, lamps, bulbs, speedometer and odometer. |
| 11. | Windscreen wipers | Wiper blades, Rear screen wash/wipe systems (including linkages, motors, arms and blades) |
| 12. | Catalytic converters | Exhaust systems. |
| 13. | | <p>Any other excluded parts:</p> <ul style="list-style-type: none"> ▶ Service items: (these are items listed as recommended by the manufacturer as being changed as part of regular servicing and maintenance) including: <ul style="list-style-type: none"> • Windscreen wiper blades, screen wash • Nuts, bolts and studs that are not part of a Paid Claim • Tyres • Fuel and Air filters • Spark plugs • Fluids: Anti-freeze, oil/lubricants, brake fluids, gearbox or transmission fluid, clutch fluids, coolants or screen wash - unless the relevant consumable is replaced as part of a Paid claim ▶ All body parts and trim (including motorcycle frames and fairings) ▶ Roof frames, folding roof fabric ▶ Upholstery ▶ Keys (lost or stolen) ▶ Glass and non-glass windows ▶ Air-conditioning parts – unless their failure has directly caused a breakdown ▶ Consumables: Oils, filters and anti-freeze unless the relevant consumable is replaced as part of a Paid claim ▶ Parts for Motorhomes that are not directly required for driving the vehicle such as fridges, cookers, drinking water suppliers, toilets etc. |

Warning lights: Please be aware that if a warning light, which is linked to an insured part, is illuminated it does not necessarily mean that the repair or replacement of the relevant insured part is required and/or will be paid for under Your AA Breakdown Repair Cover policy.

General Exclusions (This policy will not cover):

1. Any costs for repairs following a Mechanical or Electrical Failure if:
 - a. The faults existed prior to the purchase of this cover; or
 - b. The Mechanical or Electrical Failure was caused by faults, which You were aware of prior to the start of the journey on which the Breakdown occurred; or
 - c. The fault has been identified to You as part of either regular maintenance, MOT or at the point of another repair; or
 - d. The Mechanical or Electrical Failure is caused by You or anyone the AA has not authorised to carry out a repair; or
 - e. You referred the failure to a garage before You called for assistance under your AA membership; or
 - f. Repairs for the Mechanical or Electrical Failure started before Your claim has been accepted and the AA has issued an authorisation number to the repairer.
2. Repairs to vehicles that are not nominated for cover under this policy.
3. Repairs to the Nominated Vehicle, if at point of breakdown, it is not roadworthy or otherwise unlawful to use on a public road such as having a valid MOT, Tax or insurance.
4. Repairs required due to contaminated, incorrect or any fuel not meeting the manufacturers specification being added to Your vehicle, such as adding diesel to a petrol engine or petrol to a diesel engine.
5. Repairs to the nominated vehicle if you are unable to provide proof that it has been serviced regularly in line with the manufacture's schedules.
6. Any faults identified by, or reported to, the AA mobile mechanic, AA appointed garage agent, or Your repairing garage, which did not cause the initial Breakdown.
7. Any faults due to the poor maintenance of the Nominated Vehicle, for example but not limited to cam belt failure and any resulting damage, when it cannot be established that the belt has been changed according to the manufacturer's recommendations.
8. Any cost for Mechanical or Electrical Failure caused by accidental damage, frost, freezing, blockage, water penetration, road traffic accidents, theft or vandalism.
9. Any cost for Mechanical or Electrical Failure resulting from the use of the Nominated Vehicle in any sort of competition, rally or racing of any kind.
10. Any cost of repairs caused by the failure of an excluded part, or as a direct consequence of the failure of a Modified part or an excluded part.
11. Any costs, which can be recovered under warranty or any more specific insurance policy.
12. The cost of repairing further damage if You continue to drive the Nominated Vehicle after a fault has developed.

General Conditions applicable to this policy

1. Period of cover

- a) The cover runs alongside Your AA membership and will only be valid while Your AA membership is current.
- b) Cover will run until You or the AA use their right to cancel or if Your AA membership is cancelled.
- c) If You have continuous AA Breakdown Repair Cover or Annual, or 2 year AA membership, You must ensure that Your AA membership is renewed to be able to claim on Your AA Breakdown Repair Cover. If Your AA annual or 2 year membership is cancelled, Your continuous AA Breakdown Repair Cover will also be cancelled.
- d) If AA Breakdown Repair Cover is purchased on a continuous payment basis, the Insurer is entitled to make changes to the policy terms and the premium payable, during the Period of Cover, but will always give You at least 35 days prior notice of any such changes.

2. Limitations to cover

- a) If the Breakdown occurs at home, You must have At Home (Home Start) entitlement under Your AA membership to call out the AA to attend and then claim under this policy.
- b) If You require the AA to assist with the recovery of the Nominated Vehicle, this will be provided in line with Your AA membership entitlement.
- c) You can only make a maximum of three changes of vehicle in a 12 month period.
- d) Cover cannot be transferred on the sale of the Nominated vehicle to a new owner.
- e) The Nominated Vehicle must be serviced according to the manufacturer's recommendations (including service intervals). Service and mileage records are taken from the date the vehicle is first nominated for AA Breakdown Repair Cover. Invoices from a servicing garage will be accepted as proof of servicing and such invoices may be required by the Claims Department at the time claims are made. Stamped service books are not acceptable proof. It is Your responsibility to find out the Nominated Vehicle's servicing requirements and to comply with them.

3. Claims / Repair authorisation

- a) The fact that the AA has dispatched a mobile mechanic or agent does not necessarily mean that the repair will be covered by AA Breakdown Repair Cover; this will be assessed by the Claims Department.
- b) If the Nominated Vehicle cannot be repaired at the roadside the AA will, where possible, arrange for a repair through one of their preferred networks of garages. If You wish to nominate Your own choice of professional repairer, You may do so.
- c) Any repairer appointed, whether direct by You, or on Your behalf, will carry out repair work to Your instruction and the contract for repair will be between You and the relevant repairer.
- d) Any driver entitled to request assistance from the AA under Your AA membership may make a claim on Your behalf following a Breakdown in the Nominated Vehicle.
- e) Any exploratory dismantling charges will only be paid for as part of a Paid Claim. It is Your responsibility to agree any exploratory dismantling charges with Your chosen repairer and to pay their charges if, after dismantling, Your claim is not authorised by the Insurer.

- f) Claims will be assessed in line with Manufacturer or Motor Industry standard repair times and retail price guides. The Insurer reserves the right to fit replacement parts which have not been made by the Nominated Vehicle's manufacturer but are of a similar standard.
- g) If the AA or Insurer finds that repairs were made to a vehicle, which was not Nominated or, had not been Nominated for 14 days prior to the Breakdown You will be liable for the full costs of the claim.
- h) If a claim has been paid and it is subsequently found that You have not paid Your premium for the period in which the claim occurred, the Insurer will be entitled to charge You for the full amount of the claim.
- i) If the AA has refused to provide you with breakdown assistance under Your AA membership for any reason, You will be unable to claim under Your AA Breakdown Repair Cover policy.

All repairs undertaken, must be fully guaranteed for a minimum 12 months 12000 miles. This applies to all repairs for new, second hand and reconditioned parts. If the repairs are not warranted or guaranteed for this period, then any repeat failure within 12 months or 12000 miles (whichever is the sooner) will not be covered by this policy.

4. Fraudulent Claims

If We discover that You, anybody insured under this policy or anyone acting for You has knowingly:

- ▶ made a fraudulent or false claim in full or in part or exaggerated the amount of the claim or provided false or invalid documents in support of a claim; or
 - ▶ misrepresented any answers to Our questions or withheld any relevant information in order to influence the AA, or the Insurer, to accept a claim; or
 - ▶ provided false or invalid documents in support of a claim; or
 - ▶ following an allegation or suggestion of fraud by the Insurer, the AA, or any other Insurer, withdrawn a claim, had a claim refused or declined or had a policy cancelled or made void.
- We may:

- treat Your policy as if it never existed from the date of the fraud or misrepresentation and retain any premium You have paid for this policy.
- serve You a 7 day notice of cancellation on all other policies that You hold with Us; and
- pass details to the Police and fraud prevention agencies; or
- Refuse to pay the whole of Your claim if any way fraudulent, false or exaggerated and recover from You any costs that have been incurred.

5. Cancellation rights and procedures.

Cancellation by You

You have the right to cancel this policy within 14 days of the Policy Start Date (the 'cooling off' period) or from receipt of your policy documentation whichever is later.

If You cancel this policy during the cooling off period, but on or after Your cover commences, and no claim has been made, You will be entitled to a full refund of Your total payment. If a claim has been made during this period then You may still be entitled to a refund of Your total payment but You will need to repay the Insurer the full amount of the claim. If You cancel this policy after the cooling off period, You will not be entitled to a refund regardless of whether or not a claim has been made, except when cancellation is requested by or on behalf of a Member because the AA membership ceases to be of benefit to the Member for one of the following reasons:

1) death of the Member or, where the AA membership is Joint or Family, death of any other nominated person on the AA membership;

2) you are permanently unable to drive due to illness or injury (where the AA membership is Joint or Family, this will also apply to any other nominated persons on the AA membership)

Any refund will be on a pro rata basis.

We reserve the right to require the production of appropriate evidence to prove the reason for cancellation where a pro rata refund is claimed.

Suspension is not available with Breakdown Repair Cover. If you have suspended your AA membership, we will cancel your Breakdown Repair Cover and provide a pro rata refund for the remaining period of cover, calculated on a daily basis.

If you pay for Breakdown Repair Cover on a continuous monthly basis you must contact the AA on 0343 316 4444 in order to cancel your Continuous AA Breakdown Repair Cover. Outside of the 'cooling off' period You must give a minimum of 30 days notice of cancellation.

If you wish to contact the AA about cancelling your policy either call us on the number above or you can write to us at:

Member Administration, The Automobile Association, Lambert House, Stockport Road, Cheadle, Cheshire SK8 2DY
Fax: 0161 488 7544

Cancellation by the Insurer

The insurer may cancel this policy by sending at least seven days written notice to Your last known address. A full pro rata refund will be allowed from the date of cancellation regardless of whether a claim has been made under this policy.

Cancellation by AAIS

AAIS shall have the right to cancel Your AA Breakdown Repair Cover at any time. If You pay for Breakdown Repair Cover on a continuous basis they will give at least 45 days notice. Cancellation will take effect at the next payment date following the end of this notice period and no refund will be due to Members on monthly continuous contracts, however for those on quarterly continuous contracts a partial refund of unused premium may be due if cover is cancelled prior to the next payment date.

If Your AA membership is cancelled, Your AA Breakdown Repair Cover will also be cancelled.

6. The law and language, which applies to the policy.

You and the Insurer are free to choose the law applicable to this policy but in the absence of agreement to the contrary, the law, which will apply, is the law of England and Wales.

The Terms and Conditions and all other information concerning this policy are supplied in the English language and We undertake to communicate in this language for the duration of the policy. Save for the rights granted to Automobile Association Insurance Services Limited under this policy any person or company who is not a party to this contract does not have any rights they can enforce under this contract by virtue of the Contracts (Rights of Third Parties) Act 1999 except those they have by law.

Frequently asked questions

Do I have to keep my vehicle serviced regularly?

Yes. All cars require regular maintenance. Once you have nominated a vehicle for AA Breakdown Repair Cover then you will need to keep it serviced in accordance with the manufacturer's recommendations. You may be asked to produce evidence of servicing when you make a claim so be sure to retain your receipts and invoices. Stamped service books are not acceptable proof. Servicing must be done by a professional garage business and failure to keep your vehicle properly maintained may invalidate your claim.

Can I use a non VAT registered garage for my repairs?

Yes, you may use any professional repairer to complete your repairs.

Can I take my vehicle directly to a garage?

No. You must first request assistance under your AA membership.

Can I claim straight away?

No, there is a 14 day claim exclusion period from the start date of the policy or from the date any vehicle is changed or added on the policy. This cover will not pay for repairs to faults occurring within that period.

Will it cover parts like my clutch or gearbox?

This policy will cover repairs to and replacement of parts that have suffered a sudden failure; gearboxes and clutches can suddenly fail. However, this policy will not cover faults that you will have been made aware of as part of your regular maintenance (MOT, servicing etc.) or parts that have clearly been deteriorating for some time.

The cover specifically excludes repairs to the friction plates of a clutch or caused by the friction plate failing as these are specifically designed to wear over a period of time or mileage.

Can I cover other vehicles?

Yes you can cover up to 4 vehicles on a single policy, if you require cover for more than 1 vehicle you must nominate any vehicles you want to be covered under this policy.

What do I do if I change my vehicle?

You can easily update your policy to cover your replacement vehicle (please check eligibility requirements for your new vehicle). All you need to do is call us on 0343 316 4444.

Do ensure that you notify us promptly when you purchase a replacement vehicle to ensure that the new vehicle is covered as soon as possible. You will not be able to make a claim for that vehicle if it breaks down within the first 14 days after you have notified us of the change .

If You have AA Motor Insurance and have advised our Insurance team of a change of vehicle, please be aware that you will still need to call us on 0343 316 4444. Unfortunately we cannot currently update your AA Breakdown Repair Cover policy automatically from your motor insurance details.

Who can I talk to if I still have questions?

If you have any further queries then please call us on 0343 316 4444.

IF YOU NEED TO COMPLAIN

We aim to provide you with a high level of service at all times. However, there may be a time when you feel that our service has fallen below the standard you expect. If this is the case and you want to complain, we will do our best to try and resolve the situation.

There are several ways you can contact us:

Phone: 0344 209 0556

Email: customersupport@theaa.com

Post: Member Relations

The Automobile Association
Lambert House
Stockport Road
Cheadle,
Cheshire SK8 2DY

Fax: 0161 488 7544

Text Phone users can contact us using Next Generation Texting by prefixing any of our numbers with 18001.

We will either acknowledge your complaint within 5 working days of receipt, or offer you our final response if we have concluded our investigations within this period.

If we acknowledge your complaint, we will advise you who is dealing with it and when we expect to respond.

We aim to respond fully within 8 weeks. However, if we are unable to provide a final response within this period we will write to you before this time and advise why we have not been able to offer a final response and how long we expect our investigations to take.

If you remain unhappy with our final response, or we have not managed to provide a final response within 8 weeks of your complaint, you may refer your complaint to the Financial Ombudsman Service for help and advice.

Phone: 0800 023 4567 or 0300 123 9 123

Website: www.financial-ombudsman.org.uk

Email: complaintinfo@financial-ombudsman.org.uk

Post: The Financial Ombudsman Service

Exchange Tower
London
E14 9SR

Please note that consumer disputes relating to a product or service that has been bought online may be submitted to the European Commission Online Dispute Resolution platform at the following website : <http://ec.europa.eu/odr>.

**Part 2: AA Breakdown Repair Cover Arrangement
& Administration Contract – Your Contract
With Automobile Association Insurance Services
Limited (AAIS)**

AA Breakdown Repair Cover arrangement & administration contract

Set out below are the Terms and Conditions of your contract with us, Automobile Association Insurance Services Limited (AAIS), regarding our arrangement and administration of your AA Breakdown Repair Cover Policy.

Please note that some sales are not arranged through AAIS and if this applies to your cover, you will be issued with a separate document identifying the company which arranged your cover, and giving the required information about that company. The minimum duration of your arrangement and administration contract with AAIS is the duration of your AA Breakdown Repair Cover Policy and your contract with AAIS will end at the same time that the related AA Breakdown Repair Cover ends (whatever the reason for termination).

1. Who regulates AAIS?

AAIS is authorised and regulated by the Financial Conduct Authority. The Financial Conduct Authority is an independent body that regulates the financial services industry in the UK. AAIS's permitted business is that of an insurance intermediary dealing in and arranging contracts of general insurance. You can check this information on The Financial Services Register by visiting their website www.fca.org.uk The registration number is 310562.

2. Which companies does AAIS deal with?

AA Breakdown Repair Cover is underwritten by Acromas Insurance Company Limited and AAIS presently acts only for this insurer in relation to this product. AAIS acts as an agent of this insurer, when arranging payments or refunds of your premium and when making any claims payments. AAIS may renew your cover to a different insurer or notify you of a future change if the insurer of AA Breakdown Repair Cover has changed for new policies for any reason.

3. What services does AAIS provide? AAIS provides the following services to you:

- ▶ Providing information about AA Breakdown Repair Cover: AAIS will provide you with information about AA Breakdown Repair Cover and will ask you some questions to help narrow down the selection of products of interest to you. You will not receive advice or any recommendation and you will need to make your own choice about how to proceed.
- ▶ Arranging AA Breakdown Repair Cover: Once you decide what cover you require, AAIS will arrange this for you with the insurer, dealing with payment and issuing the relevant documentation.
- ▶ Administering AA Breakdown Repair Cover: After arranging the AA Breakdown Repair Cover Policy, AAIS will administer it on your behalf, including supplying replacement documentation, keeping your policy records up to date and dealing with enquiries, changes to payment methods; renewals (including auto-renewal) of AA Breakdown Repair Cover and cancellations (including refunds on behalf of the insurer(s)).
- ▶ If you have agreed to pay for AA Breakdown Repair Cover by continuous monthly premiums and a premium is overdue or missed, AAIS may arrange to collect the payment from the credit card or debit card supplied for the initial payment, in order to ensure you remain covered. We will advise you in writing before doing this. Unless otherwise notified, we will then continue to collect payment using this method, but will advise you in writing that we are doing this.

- ▶ If during the life of your policy the relevant insurer wishes to alter the Terms & Conditions of the policy AAIS will provide you with the relevant information.
- ▶ AAIS will, for compliance purposes, keep a copy of the policy that was issued to you. Communication by AAIS concerning any policy issued will be in English.

AAIS act for the insurer(s) in marketing their insurance products: AAIS is authorised to act for the insurer when entering into a contract of insurance with you on their behalf. AAIS may receive and retain commission from the insurer in respect of any insurance that you take out through it.

4. What will you have to pay for services provided by AAIS?

AAIS will always inform you of, or confirm, in writing its fees for the services it provides under this contract. These fees will be advised in the contract, in the accompanying letter, or separately in writing and will be identified separately from the premium. Subject to any statutory rights you may have, AAIS will not refund any of its fees except where it has arranged a refund of premium following cancellation in the cooling off period of the AA Breakdown Repair Cover Policy. AAIS will also tell you about any other charges relating to your AA Breakdown Repair Cover.

5. Changes to Terms & Conditions Annual cover:

AAIS is entitled to change any of these Terms & Conditions at renewal. AAIS also reserves the right to make changes to these Terms & Conditions during the policy year, or 2 year contract, on the giving of reasonable notice, where it reasonably considers this necessary in order to comply with any applicable laws, regulations or the advice or instruction of any regulatory authority.

For Continuous cover, AAIS is entitled to make changes to any of these Terms & Conditions (and to the fees payable) during a Continuous contract, but will always give at least 35 days prior notice of any such change(s).

6. Matters outside AAIS's reasonable control

AAIS shall not be liable for service failures where it is faced with circumstances outside its reasonable control. Events which might constitute circumstances outside AAIS's reasonable control include (but are not limited to) Acts of God, outbreak of hostilities, riot, civil disturbance, acts of terrorism, acts of government or authority (including the refusal or revocation of any licence or consent), fire, subsidence, explosion, flood, snow, fog or other bad weather conditions, vehicle equipment or system failures, shortages of fuel or other necessary supplies, failure of telecommunications lines or systems, default of suppliers or sub-contractors, theft, malicious damage, strike, lock out or industrial action of any kind.

7. Exclusion of liability for loss of profit etc. AAIS shall not, in any event, and to the extent permitted by law, have any responsibility for

- (a) any increased costs or expenses;
- (b) any loss of
 - (i) profit
 - (ii) business
 - (iii) contracts
 - (iv) revenue or
 - (v) anticipated savings; or

(C) for any special or indirect losses incurred as a result of or in connection with any service, whether resulting from tort (including negligence or breach of statutory duty), from breach of contract or otherwise.

For the avoidance of doubt, nothing in this clause or these Terms & Conditions shall exclude or restrict AAIS's liability for negligence resulting in death or personal injury.

8. Third parties

None of the Terms and Conditions, or benefits, of this contract are enforceable by anyone else other than the insured. For the avoidance of doubt, and without limiting the above, any rights under The Contract (Rights of Third Parties) Act 1999, or any replacement or amendment of such act, are excluded.

9. Interpretation: Use of English Law and Language

This contract is written in English and is governed by, and should be interpreted under, the laws of England and Wales.

10. What to do if You have a compliment or complaint

If You wish to register a compliment or complaint about the services You have received from AAIS under this AA Breakdown Repair Cover Arrangement and Administration Contract please contact Member Relations by phone: 0344 209 0556 or in writing to: Member Relations, AAIS, Lambert House, Stockport Road, Cheadle, Cheshire, SK8 2DY or by email: customersupport@theAA.com.

If You remain dissatisfied with the final response to a complaint, You can also contact the Financial Ombudsman Service for help and advice (see contact details on page 19).

11. Is AAIS covered by the Financial Services Compensation Scheme (FSCS)?

AAIS is covered by the FSCS. You may be entitled to compensation from the scheme if AAIS cannot meet its obligations in arranging AA Breakdown Repair Cover. General insurance provided by a regulated insurer such as Acromas Insurance Company Limited is covered for 90% of the claim, without any upper limit. Further information about compensation scheme arrangements is available from the FSCS at www.fscs.org.uk. Alternatively by telephone on either 0800 678 1100 or 0207 741 4100.

12. Use of headings

The headings used above are for convenience only and shall not affect the interpretation of its contents.

For claims please call 0344 579 0042

Use of your personal information

For information on how we use your data - please see the AA's privacy wording in your Membership Terms and Conditions booklet or for more information visit theaa.com/privacy-policy

AA company details

Automobile Association Developments Limited, trading as AA Breakdown Services, is an insurer of breakdown assistance services cover that is exempt from authorisation under the Financial Services and Markets Act 2000. Registered office: Fanum House, Basing View, Basingstoke RG21 4EA. Registered in England and Wales Number: 01878835.

Automobile Association Insurance Services Limited is an insurance intermediary authorised and regulated by the Financial Conduct Authority. Registered office: Fanum House, Basing View, Basingstoke, Hampshire RG21 4EA. Registered in England and Wales Number: 2414212.

Your responsibilities

Please be sure to read this booklet carefully, taking care to check that you comply with the Terms & Conditions of AA Breakdown Repair Cover, in particular:

- ▶ That your nominated vehicle is eligible for cover
- ▶ Your vehicle must have broken down and have been attended by the AA under your AA membership.

Ensure that you keep your vehicle serviced in line with the manufacturer's recommendations by a suitable garage business. Be sure that you keep your invoices or receipts for servicing carefully as we may require proof of servicing when you make a claim. You may wish to keep copies in the vehicle to help make the claims process even faster.

Ensure that you inform us if you change your vehicle. You will need to provide the vehicle's registration number, make, model, mileage and date of first registration when you call on 0343 316 4444 to make the change.

Put your Claims Guide in your vehicle's glovebox so you'll have the Claims Helpline telephone number when you need it.

Useful Contact Information:

To make changes to your policy: **0343 316 4444**
(Monday to Friday 8am to 8pm, Saturday 9am to 5pm)

To make a complaint: **0344 209 0556**
(Monday to Friday 9am to 5pm)

To make a claim: **0344 579 0042**
(Monday to Friday 9am to 6pm, Saturday 9am to 1pm)